

ASTRONOMY 220C

ADVANCED STAGES OF STELLAR EVOLUTION AND NUCLEOSYNTHESIS

Winter, 2019

<http://www.ucolick.org/~woosley>

This is a one quarter course dealing chiefly with:

- Nuclear astrophysics and the relevant nuclear physics
- The evolution of massive stars - especially their advanced stages
- Nucleosynthesis – the origin of each isotope in nature
- Supernovae of all types
- First stars, ultraluminous supernovae, subluminous supernovae
- Stellar mass high energy transients - gamma-ray bursts, novae, and x-ray bursts.

Our study of supernovae will be extensive and will cover not only the mechanisms currently thought responsible for their explosion, but also their nucleosynthesis, mixing, spectra, compact remnants light curves, and multi-messenger astronomy.

The student is expected to be familiar with the material presented in Ay 220A and thus to already know the essentials of stellar evolution, as well as basic quantum mechanics and statistical mechanics.

The course material is extracted from a variety of sources, much of it the results of local research. It is not contained, in total, in any one or several books. The powerpoint slides are on the web, but you will need to come to class. A useful textbook, especially for material early in the course, is Clayton's, *Principles of Stellar Evolution and Nucleosynthesis*. Also of some use are Branch and Wheeler's *Supernova Explosions* and Kippenhahn and Weigert's *Stellar Evolution and Nucleosynthesis* (both published by Springer Verlag).

Course performance will be based upon four graded homework sets and an in-class final examination.

The anticipated class material is given, in outline form, in the following few slides, but you can expect some alterations as we go along. The course will begin with material that is more "classical" in nature, especially some basics of nuclear reaction theory. By mid-quarter however, we should advance to more current, and consequently less certain results and challenges.

Author	Title	Approximate price	Comments
O. R. Pols	<i>Stellar Structure and Evolution</i>	Free (on line)	Good overall introduction to stellar evolution at the upper division undergraduate level.
Kippenhahn and Weigert	<i>Stellar Structure and Evolution</i>	\$88.67 (hardcover)	Great "introductory" textbook (more for 220A though)
Branch and Wheeler	<i>Supernova Explosions</i>	\$109.81	Excellent recent (2017) book on just the supernova part of the course. Expensive. Can be "rented" for half price.
Don Clayton	<i>Principles of Stellar Evolution and Nucleosynthesis</i>	\$<40.85 (paperback)	A classic. Great on nuclear physics and basic stellar physics. Good on the s-process, but quite dated otherwise. Used \$10.00

Abundances Now and Then

What, where, and how?

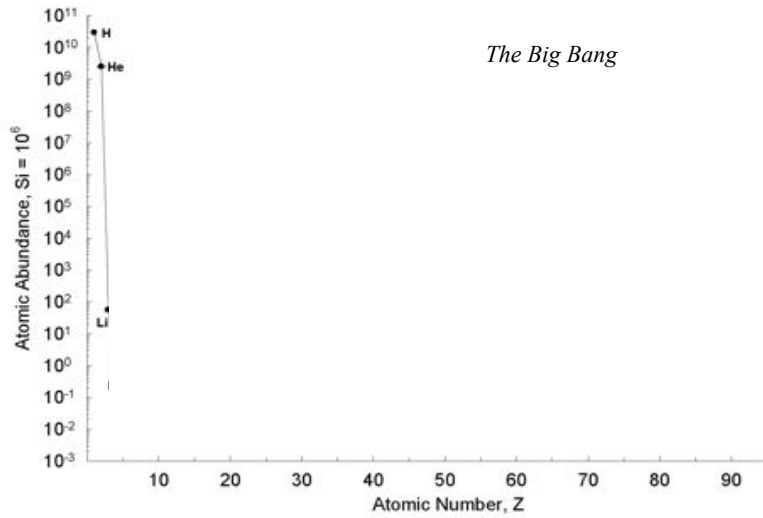

The Big Bang

Abundances Now and Then

What, where, and how?

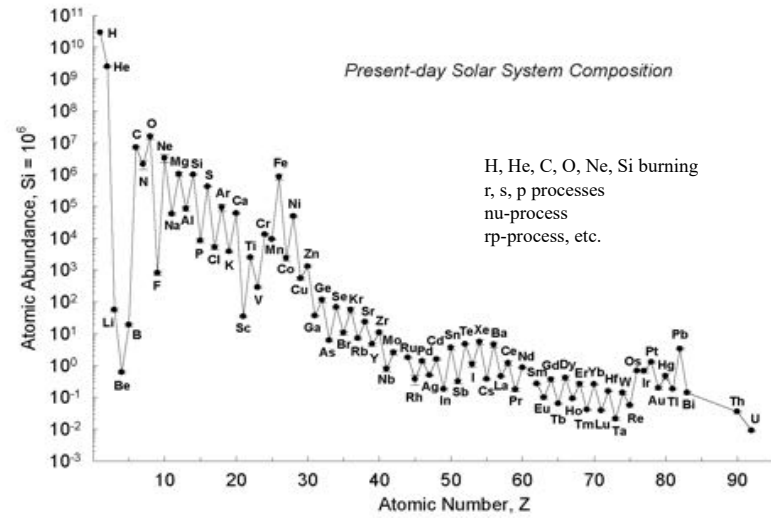

Present-day Solar System Composition

H, He, C, O, Ne, Si burning
r, s, p processes
nu-process
rp-process, etc.

Nuclear Physics

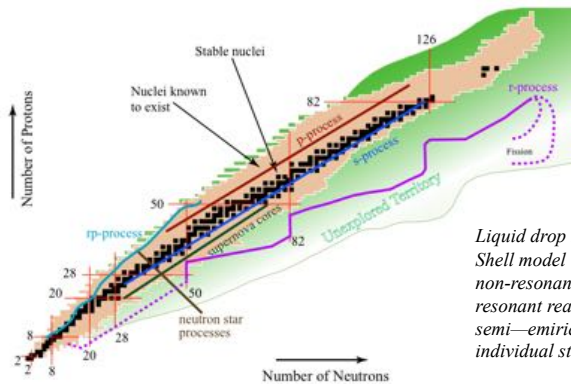

Liquid drop model
Shell model
non-resonant reactions
resonant reactions
semi-empirical estimates
individual stellar cross sections

Typical nuclear data deck for stellar nucleosynthesis studies (BDAT) includes 5442 nuclei and 105,000 reactions (plus their inverses). Fortunately not all are equally important. Most (non-r-process) studies use about 1/3 of this.

Stellar Evolution

And the physics to study it with:

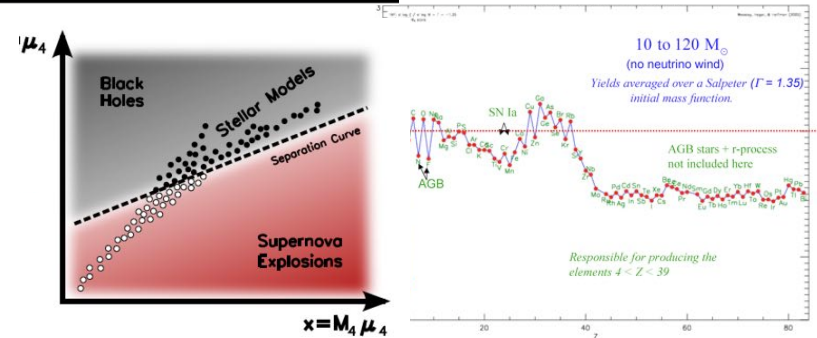
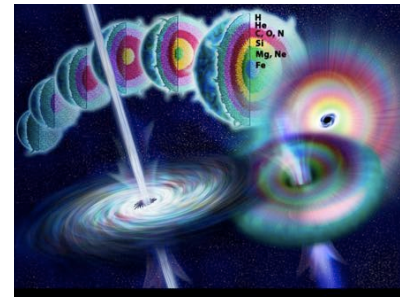

Supernovae

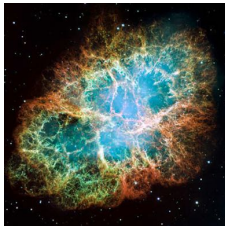
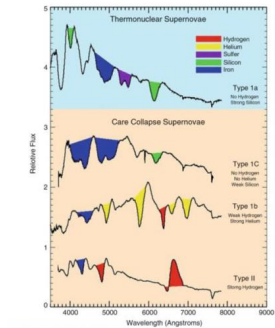

All types:

Ia, Ib, Ic, II p, II L, II L-n, BL SN Ic, I ap, etc.

And Models

*Exploding white dwarfs
Chandrasekhar
sub-Chandrasekhar
Merging WDs*

Massive star (gravity powered)

*Neutrino transport
Magnetar powered*

Massive star (thermonuclear)

*Pulsational Pair
Pair
GR unstable*

Colliding shells

1. *Introduction and overview* – course overview. General principles of stellar evolution – temperature-density scalings, critical masses, entropy, abundances in the cosmos, some simple aspects of Galactic chemical evolution.

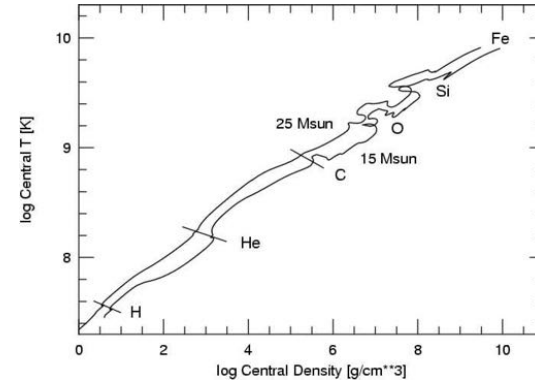

2. *Abundances* – Abundances in the sun and meteorites. Abundances in other stars, especially low metallicity stars. Abundance evolutionary trends. Some aspects of galactic chemical evolution

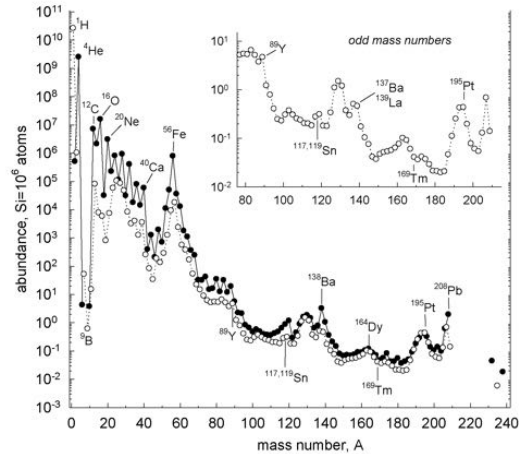

3) *Nuclear Physics - 1* - The nuclear force. Physics of the atomic nucleus. Binding energy. The liquid drop model.

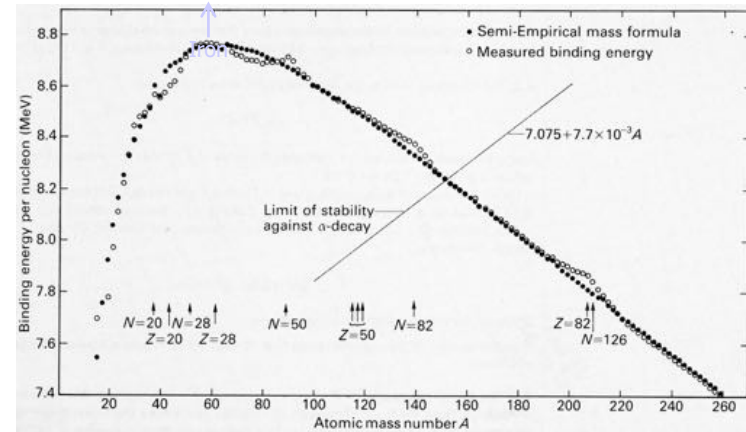

4) Nuclear physics – 2 The shell model

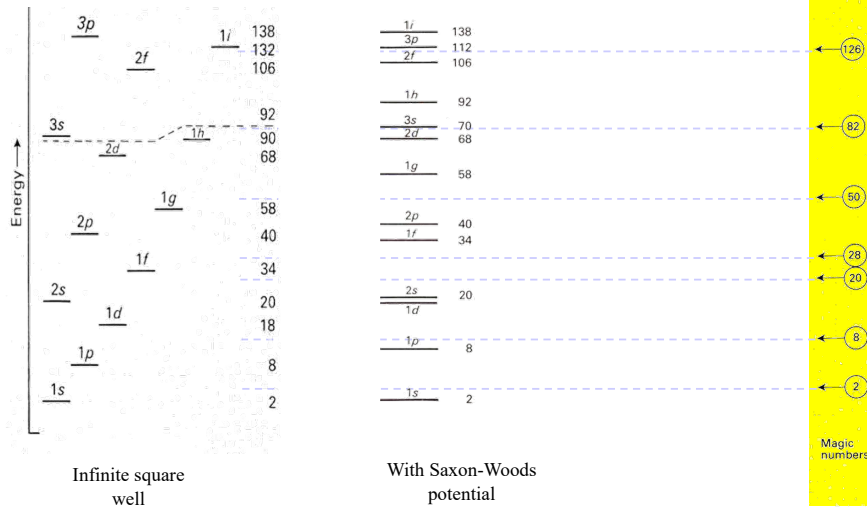

5) Nuclear Physics – Nuclear reaction theory. Astrophysical reaction rates. Resonant and non-resonant rates

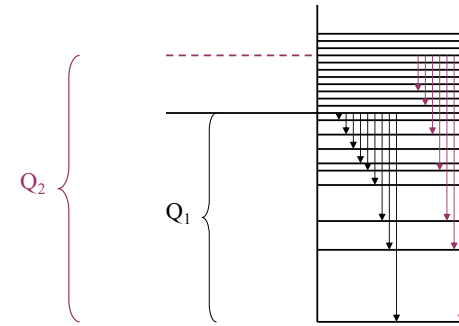

6) Some key rates for astrophysics.

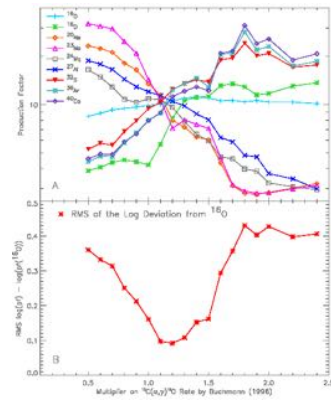
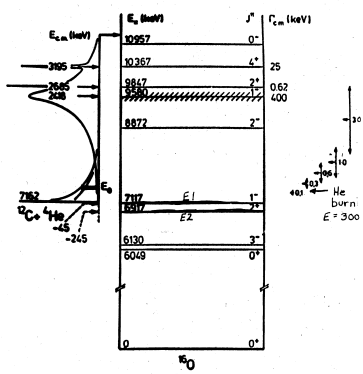

7 and 8) The evolution of massive stars on the main sequence and as red giants – general properties of massive stars, convection, semi-convection, mass loss, rotation, nucleosynthesis, metallicity dependence, Wolf-Rayet stars.

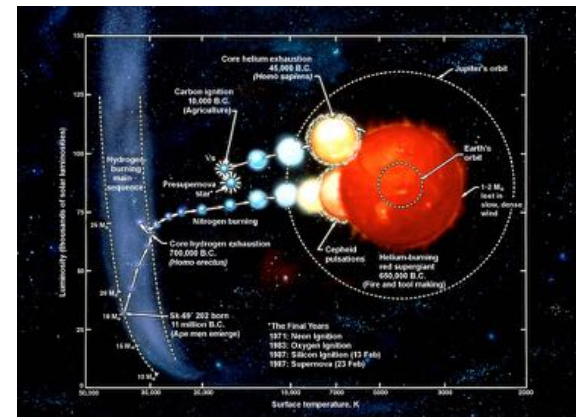

9. *Hot hydrogen burning* – classical novae and x-ray bursts on neutron stars

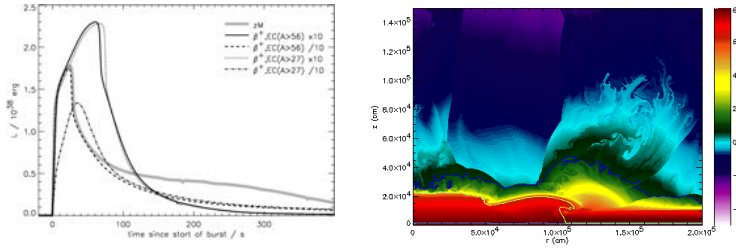

10. *The s-process* – Helium burning and the s-process
 Relevant nuclear physics, abundance systematics, solving the rate equations, occurrence in massive stars and AGB stars

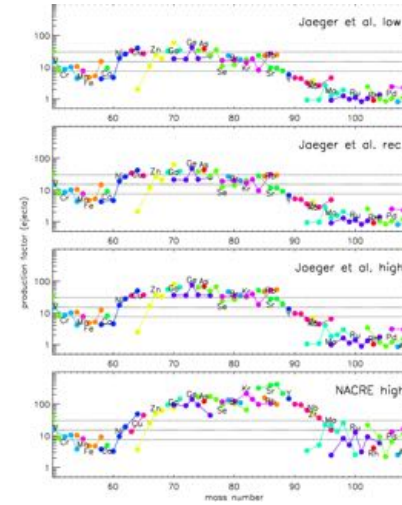

11) *Neutrino losses and the advanced burning stages in massive stars* – Thermal neutrino losses, nuclear physics of carbon, neon, oxygen and silicon burning. Concepts of balanced power and nuclear quasi-equilibrium.

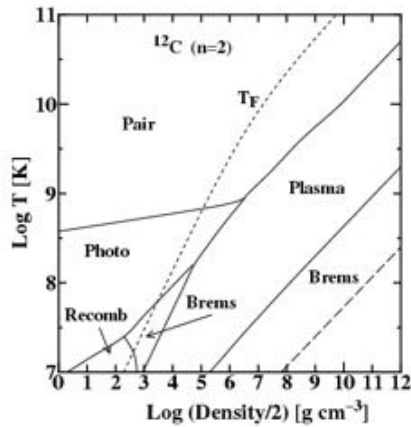

Physical processes dominating the energy loss from plasmas at different temperatures and densities.

12) *Advanced evolution of model stars in the 8 to 70 solar mass range* – Silicon burning, quasiequilibrium, nuclear statistical equilibrium. Onset of core collapse.

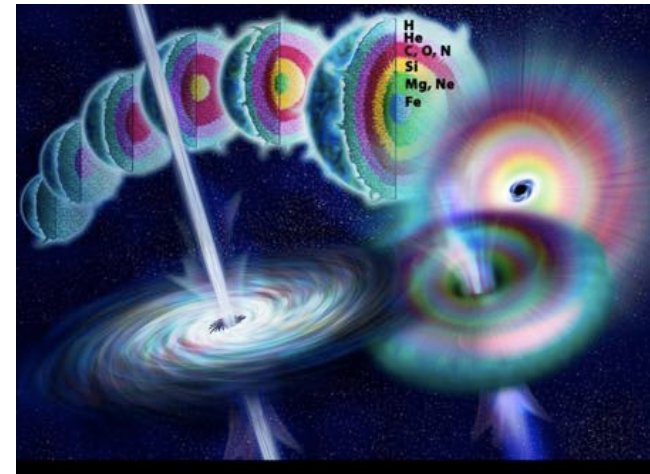

13) Presupernova models, core collapse and bounce –
 Current models in 1, 2 and 3D. Limits of the mechanism.
 Role of rotation and magnetic fields.



14) Explosion and mixing – Observation and physics.
 Fall back. Neutron star and black hole birth.

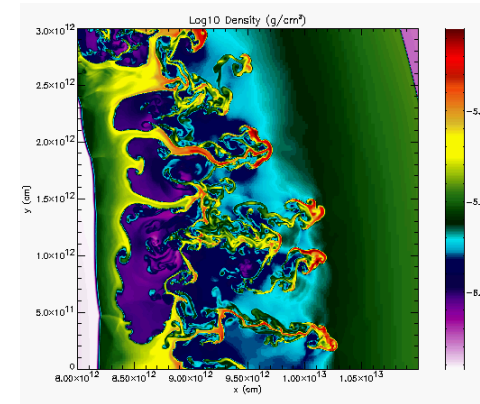

15) Explosive nucleosynthesis and the r-Process – General properties.
 Products and uncertainties. Possible sites. The neutrino powered wind.

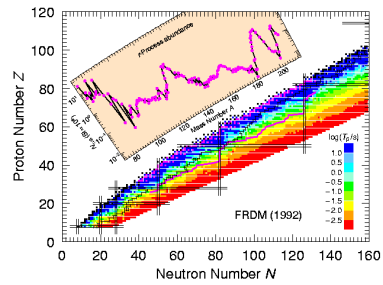
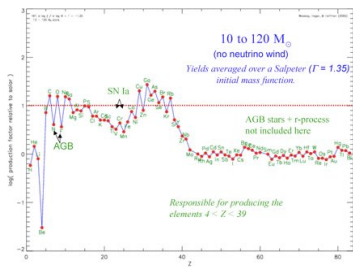

16) Observational aspects of core-collapse supernovae
 - spectra and light curves. Neutrino signal. Gamma-ray
 line astronomy. Shock break out.

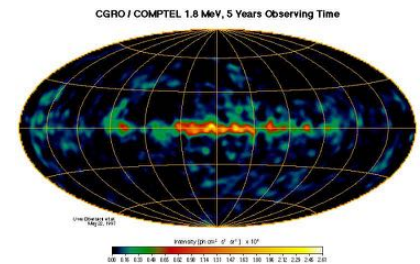
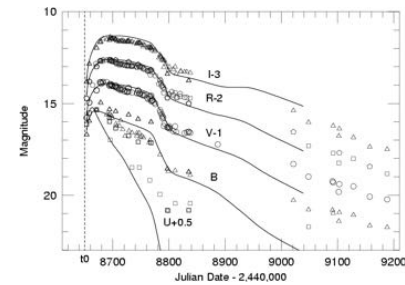

17) Evolution in Mass Exchanging Binaries

- Everything is different. Masses of progenitors, light curves, etc.
 Yet all our information on masses and LIGO sources comes from binaries.

(Common) Type Ib and Ic supernovae

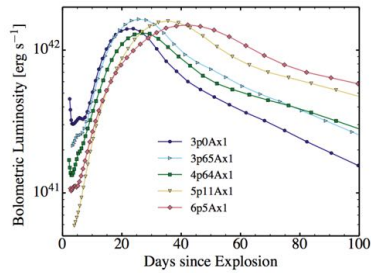

Dessart et al (MNRAS, 2015)

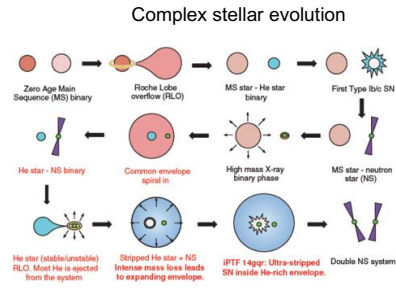

De et al (Science, 2018)

18) Type Ia supernovae – Models and how they explode. Chandrasekhar mass models, sub-Chandrasekhar mass models, Merging white dwarfs



MARPLED simulations visualization of a non-rotating white dwarf (left) and a 1.2% prolate rotating white dwarf (right) exploding as Type Ia supernovae. Each visualization shows interaction of ejecta with an effective 10¹⁰ M_⊙ point (i.e. the specific model).

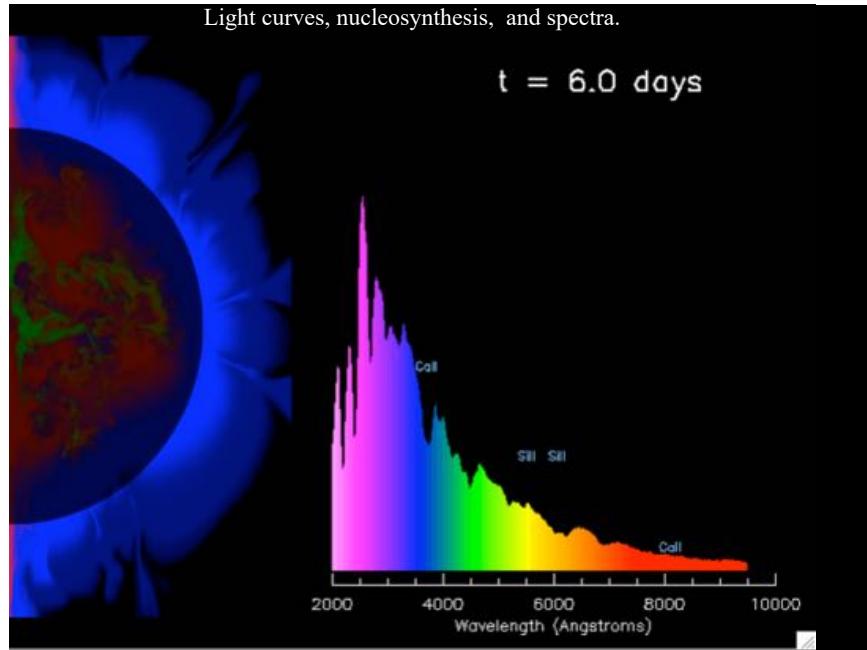

19) Unusual supernovae – Pair instability and pulsational pair instability supernovae. Magnetar powered supernovae nucleosynthesis, light curves.

First generation stars may have formed with higher masses and almost certainly died with higher masses.

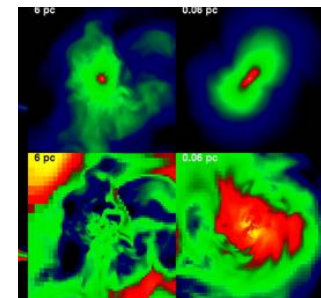

Starting at ~80 solar masses (31 solar mass helium core) the pulsational pair instability sets in.

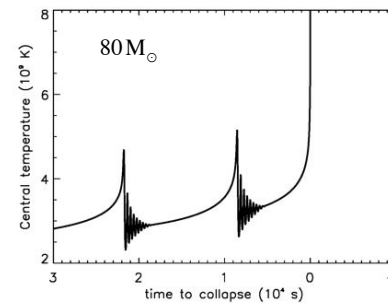

20) . More unusual supernovae, superluminous supernovae and gamma-ray bursts –

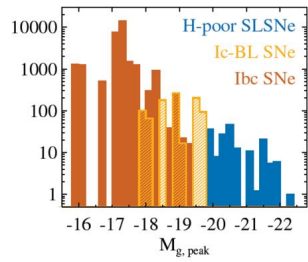

Gal-yam (ARAA 2018)

*Models: Collapsars
and magnetars*

Observations

